



TTLM

AHCS L-1

## **Animal Health Care Service Level I**

# **Learning Guide -18**

**Unit of Competence: -Use and Maintain Basic  
Tools and Equipment**

**Module Title: - Using and Maintaining Basic  
Tools and Equipment**

**LG Code: AGR AHC1M06 LO1-LG-18**

**TTLM Code: AGRAHC1 TTLM06 09 19v1**

**LO1: Prepare basic tools and equipment for use**



This learning guide is developed to provide you the necessary information regarding the following **content coverage** and topics –

- identifying and selecting tools and equipment
- carrying out routine pre-operational checks of tools and equipment
- identifying and segregating Unsafe or faulty machinery and equipment for repair or replacement
- identifying and reporting OHS hazards in the workplace

This guide will also assist you to attain the learning outcome stated in the cover page. Specifically,

- identify and select tools and equipment
- Carry out routine pre-operational checks of tools and equipment
- identify and segregate Unsafe or faulty machinery and equipment for repair or replacement
- identify and report OHS hazards in the workplace

#### **Learning Instructions:**

1. Read the specific objectives of this Learning Guide.
2. Follow the instructions described in number 3 to 7.
3. Read the information written in the “Information Sheets 1”. Try to understand what are being discussed. Ask you teacher for assistance if you have hard time understanding them.
4. Accomplish the “Self-check 1”,2,3, and 4 **in page -.6,9,12 and 16 respectively**
5. Ask from your teacher the key to correction (key answers) or you can request your teacher to correct your work. (You are to get the key answer only after you finished answering the Self-check 1).
6. If you earned a satisfactory evaluation proceed to “Information Sheet 2”. However, if your rating is unsatisfactory, see your teacher for further instructions or go back to Learning Activity #1.
7. Submit your accomplished Self-check. This will form part of your training portfolio.

**Information Sheet-1****Identifying and selecting tools and equipment****What is a Tool?**

Any physical item that is used to achieve a goal but is not consumed during this process can be defined as a tool. Informally speaking, it can also be used to describe a specific procedure with a specific purpose as well

**What is Equipment?**

It is a set of tools that are designated for a specific task is known as equipment. This could be a small set of functional items in a finished product. For example, equipment of a car may be alternators, absorbers, optical, electronic boxes, etc. Equipment of a house may be appliances while equipment may also include all sorts of devices needed for a specific task.

**Tools and Equipments that are used for animal health service may include:****➤ Refrigerator**

It is used for

- ✓ To stores media, reagents, antibiotic and others substances,
- ✓ To prolong the life of specimen
- ✓ To arrests deterioration

**The refrigerator is divided into two compartments-**

- ✓ The **freezing compartment**: the temperature of the freezing compartment is usually between -15 to -20°C.
- ✓ The **cooling compartment**: used to keeping antibiotics, vaccines, serum etc

**➤ Microscope**

**Microscope**: is an apparatus w/c is widely used for the magnification of micro-organisms and d/t oocyte from the sample

- **Bacteriological incubator**: Incubators are commonly used for growing bacterial cultures in the microbiology laboratory
- **Autoclave**: An autoclave is the most effective and most commonly used for equipment sterilization.
- **Centrifuge**: is a device by which suspension of solid material in liquid phase is rotated at high speed this accelerates the sedimentation process by using centrifugal force. As a result, the solid phase separates out and forms the sediment at the bottom, and the liquid forms the supernatant at the top

**Centrifuges are two types**



1. Hand (manual) centrifuge. The hand centrifuges can hold only two to four centrifuge tubes, which are of 15ml capacity, and usually made of aluminium which can reach up to 2,000 to 2,500 rotations per minute (rpm).
2. Electric centrifuge. The electric centrifuges are motor- driven centrifuges, operated through mains electrical supply. These can reach up to 3500 rpm and they are usually provided with multistage speed regulator to obtain desired speed. The common laboratory centrifuge is used for separation of serum and sediments of

- **Electrical sterilizer:** used to clean clinical instruments
- **Stethoscope:** for auscultation of heart and lung
- **Treatment syringe:** to give injection of medicines
- **Vaccination syringe:** to give vaccines to protect infection and are two types namely manual and automatic.
- **Thermometer:** to record body temperature of animal which are two in type (mercuric and digital)
- **Burdizzo:** used for castration of cattle, equine, sheep and goat
- **Treatment Needle:** used for administering of drug treatment to the patient

For example, an 18-gauge needle is smaller than a 16-gauge needle. Longer needles are used for intramuscular injections (1 1/2") and shorter needles (1/2" to 1 ") for subcutaneous injections. Dogs and Cats – 20 or 22 gauges with 1/2" to 1" length

The needle recommendations are given in length x diameter (gauge).

Recommended Needle Sizes			
	Subcutaneous (SQ)	Intramuscular (IM)	Intravenous (IV)



TTLM

AHCS L-1

Dog & Cat	$\frac{3}{4}$ " x 22 ga	1" x 22 ga	***
Horse	1" x 18 ga	1 $\frac{1}{2}$ " x 18 ga	1 $\frac{1}{2}$ " x 18 ga
Colt	$\frac{3}{4}$ " x 20 ga	1" x 20 ga	1" x 20 ga
Cow	1" x 16 ga	1" x 16 ga	1 $\frac{1}{2}$ " x 16 ga
Calf	$\frac{3}{4}$ " x 16 ga	1" x 16 ga	1" x 18 ga
Goat	$\frac{3}{4}$ " x 22 ga	1" x 18 ga	***
Sheep	$\frac{3}{4}$ " x 18 ga	1" x 18 ga	1" x 18 ga
Hog	$\frac{3}{4}$ " x 18 ga	1" x 18 ga	2" x 18 ga
Sow	1" x 18 ga	1" x 18 ga	4" x 18 ga
Pig	$\frac{1}{2}$ " x 20 ga	1" x 18 ga	1" – 1 $\frac{1}{2}$ " x 20 ga
Poultry	$\frac{5}{8}$ " x 25 ga	$\frac{3}{4}$ " x 22 ga	***
<p><b>NOTE:</b> The smaller the gauge (ga) the bigger the needle (diameter).</p>			

- **Vaccination needle**
- **Petry dish:** To hold sample
- **Surgical try:** to hold materials needed during treatment or surgery case
- **Boling gun:** to give medicine to anima in solid form which are two in type (small and large)
- **Drenching gun:** to give medicine to animal in fluid form
- **Forceps:** to hold tissue and others
- **Scissors:** for general use in cutting purpose (types)
- **Trocar and cannula:** to remove gas from rumen in bloat
- **Beaker: for measuring solution**
- **Graduated cylinder:** for measuring solution
- **Hammer:** for percussion of organ to detect pain



**TTLM**

**AHCS L-1**

- **Casting rope:** to throw animal on the ground and bring under control for various operations
- **Treatment syringe:** to give injection of medicines
- **Teat dialator:** to remove blockage of teat
- **Vaginal speculum:** to examine vaginal wall
- **Bunsen burner**
- **Ice box:** for sample collection
- **Dehorning saw and wire**
- **Bull holder:** for restrain of bull
- **Surgical needle:** for suturing
- **Suturing material**
- **Mouth gag:** used for opening of mouth
- **X-ray:**
- **Ultrasonography**
- **Emasculator:** open castration
- **Stomach tube (small and large)**

<b>Self-Check -1</b>	<b>Written Test</b>
----------------------	---------------------

**Directions:** Answer all the questions listed below. Use the Answer sheet provided in the next page:

1. List at least 10 tools and equipments which are used in animal health service (10 pts)

**Note: Satisfactory rating - 5 points**

**Unsatisfactory - below 5 points**

**Answer Sheet**

Score = \_\_\_\_\_

Rating: \_\_\_\_\_

Name: \_\_\_\_\_

Date: \_\_\_\_\_



<b>Information Sheet-2</b>	Carrying out routine pre-operational checks of tools and equipment
----------------------------	--

### What you must do

You should inspect work equipment if your risk assessment identifies any significant risk (for example, of major injury) to operators and others from the equipment's installation or use. The result of the inspection should be recorded and this record should be kept at least until the next inspection of that equipment. Records do not have to be made in writing but, if kept in another form (eg on a computer), these should be held securely and made available upon request by any enforcing authority.

Work equipment that requires inspection should not be used, unless you know the inspection has taken place. Where it leaves your undertaking, or is obtained from another (eg a hire company) it should be accompanied by physical evidence of the last inspection, such as an inspection report or, for smaller items of equipment, some form of tagging, colour coding or labelling system.

### What you should know

Power regulation: Specifies the circumstances where inspection is required to ensure healthy and safe conditions are maintained:

- where the safety of work equipment depends on the installation conditions, it should be inspected after installation and before first use, and after reassembly at any new site / location
- at suitable intervals, where work equipment is exposed to conditions causing deterioration liable to result in dangerous situations
- each time exceptional circumstances (eg major modifications, known or suspected serious damage, substantial change in the nature of use) are liable to have jeopardised the safety of the work equipment

What should the inspection cover?

This will depend on type of work equipment, its use and the conditions to which it is exposed. This should be determined through risk assessment and take full account of any manufacturer's recommendations. The advice of others, such as trade associations and consultants, as well as other sources like published advice on health and safety, may also be helpful.

An inspection should concentrate on those safety-related parts which are necessary for the safe operation of work equipment and, in some cases, this may require testing or dismantling. However, not all safety-critical features on a particular item of work equipment may require inspection at the same intervals.

An inspection can vary in its extent, as the following demonstrate:

- quick checks before use (eg electric cable condition on hand-held power tools, functional testing of brakes, lights on mobile machinery)
- weekly checks (eg presence of guarding, function of safety devices, tyre pressures, and the condition of windows, mirrors and CCTV on mobile plant)
- more extensive examinations, undertaken every few months or longer (eg general condition of a ladder, close examination of a safety harness, portable appliance testing)



**TTLM**

**AHCS L-1**

Records are not normally required to be made for the simplest pre-use checks.

The use of checklists can assist but these, and the records made, should be tailored to the particular type of work equipment to minimize the burden to what is strictly necessary for safety. Requiring too much detail too often can lead to inspection activity becoming burdensome with the risk of a superficial 'tick box' approach or even, in some cases, the inspection activity ceasing altogether. You only need to inspect what is necessary for safety.

### **When should work equipment that needs inspection be re-inspected?**

Work equipment which is exposed to conditions causing deterioration that could result in a dangerous situation should be inspected at suitable intervals, and after every event liable to jeopardise its safety. The frequency of inspection may vary; depending on environmental conditions (eg equipment subject to harsh outdoor conditions is likely to need more frequent inspections than if used in an indoor environment).

The frequency of inspection should be determined through risk assessment, taking account of the manufacturer's recommendations, industry advice and your own experience. It may be appropriate to review the frequency of inspection in the light of your experience. Intervals between inspections can be increased if the inspection history shows negligible deterioration, or shortened where experience shows this is necessary to prevent danger.

### **Who should carry out the inspection of work equipment?**

Equipment can be inspected by anyone who has sufficient knowledge and experience of it to enable them to know:

- what to look at
- what to look for
- what to do if they find a problem

The necessary level of competence will vary for inspections, according to the type of equipment and how / where it is used. The nature of these inspections does not have to be determined by the same person who undertakes them, provided the person determining them is competent. This can often be done in-house by experienced staff, taking account of:

- the manufacturer's recommendations
- industry advice
- their own experience of the equipment, its use, the particular factors of the workplace and the people using the work equipment

### **Types of Inspections:**

- Pre-start up, pre-operational
- Monthly plant inspection (JHSC)
- Manufacturer's recommendations
- Supervisory/management inspection
- Maintenance





**TTLM**

**AHCS L-1**

<b>Self-Check -2</b>	<b>Written Test</b>
----------------------	---------------------

**Directions:** Answer all the questions listed below. Use the Answer sheet provided in the next page:

1. List factors that determine frequency of inspection of tools and equipments (4 pts)
2. Write types of inspection (5 pts))

**Note: Satisfactory rating - 3 points**

**Unsatisfactory - below 3 points**

**Answer Sheet**

Score = _____
Rating: _____

Name: \_\_\_\_\_

Date: \_\_\_\_\_



<b>Information Sheet-3</b>	<b>Identifying and segregating unsafe or faulty machinery and equipment for repair or replacement</b>
----------------------------	---

### **What is Calibration?**

Many people do a field comparison check of two meters, and call them “calibrated” if they give the same reading. This isn’t calibration. It’s simply a field check. It can show you if there’s a problem, but it can’t show you which meter is right. If both meters are out of calibration by the same amount and in the same direction, it won’t show you anything. Nor will it show you any trending — you won’t know your instrument is headed for an “out of cal” condition.

For an effective calibration, the calibration standard must be more accurate than the instrument under test. Most of us have a microwave oven or other appliance that displays the time in hours and minutes. Most of us live in places where we change the clocks at least twice a year, plus again after a power outage. When you set the time on that appliance, what do you use as your reference timepiece? Do you use a clock that displays seconds? You probably set the time on the “digits challenged” appliance when the reference clock is at the “top” of a minute (e.g., zero seconds). A metrology lab follows the same philosophy. They see how closely your “whole minutes” track the correct number of seconds. And they do this at multiple points on the measurement scales.

Calibration typically requires a standard that has at least 10 times the accuracy of the instrument under test. Otherwise, you are calibrating within overlapping tolerances and the tolerances of your standard render an “in cal” instrument “out of cal” or vice-versa. Let’s look at how that works.

Two instruments, A and B, measure 100 V within 1 %. At 480 V, both are within tolerance. At 100 V input, A reads 99.1 V and B reads 100.9 V. But if you use B as your standard, A will appear to be out of tolerance. However, if B is accurate to 0.1 %, then the most B will read at 100 V is 100.1 V. Now if you compare A to B, A is in tolerance. You can also see that A is at the low end of the tolerance range. Modifying A to bring that reading up will presumably keep A from giving a false reading as it experiences normal drift between calibrations.

Calibration, in its purest sense, is the comparison of an instrument to a known standard. Proper calibration involves use of a NIST-traceable standard — one that has paperwork



**TTLM**

**AHCS L-1**

showing it compares correctly to a chain of standards going back to a master standard maintained by the National Institute of Standards and Technology.

In practice, calibration includes correction. Usually when you send an instrument for calibration, you authorize repair to bring the instrument back into calibration if it was “out of cal.” You’ll get a report showing how far out of calibration the instrument was before, and how far out it is after. In the minutes and seconds scenario, you’d find the calibration error required a correction to keep the device “dead on,” but the error was well within the tolerances required for the measurements you made since the last calibration.

If the report shows gross calibration errors, you may need to go back to the work you did with that instrument and take new measurements until no errors are evident. You would start with the latest measurements and work your way toward the earliest ones. In nuclear safety-related work, you would have to redo all the measurements made since the previous calibration.

### **Causes of calibration problems**

What knocks a digital instrument “out of cal?” First, the major components of test instruments (e.g., voltage references, input dividers, current shunts) can simply shift over time. This shifting is minor and usually harmless if you keep a good calibration schedule, and this shifting is typically what calibration finds and corrects.

But, suppose you drop a current clamp — hard. How do you know that clamp will accurately measure, now? You don’t. It may well have gross calibration errors. Similarly, exposing a DMM to an overload can throw it off. Some people think this has little effect, because the inputs are fused or breaker-protected. But, those protection devices may not trip on a transient. Also, a large enough voltage input can jump across the input protection device entirely. This is far less likely with higher quality DMMs, which is one reason they are more cost-effective than the less expensive imports.

### **Calibration frequency**

The question isn’t whether to calibrate — we can see that’s a given. The question is when to calibrate. There is no “one size fits all” answer. Consider these calibration frequencies:

Manufacturer-recommended calibration interval. Manufacturers’ specifications will indicate how often to calibrate their tools, but critical measurements may require different intervals.



**TTLM**

**AHCS L-1**

Before a major critical measuring project. Suppose you are taking a plant down for testing that requires highly accurate measurements. Decide which instruments you will use for that testing. Send them out for calibration, then “lock them down” in storage so they are unused before that test.

After a major critical measuring project. If you reserved calibrated test instruments for a particular testing operation, send that same equipment for calibration after the testing. When the calibration results come back, you will know whether you can consider that testing complete and reliable.

After an event. If your instrument took a hit — something knocked out the internal overload or the unit absorbed a particularly sharp impact — send it out for calibration and have the safety integrity checked, as well.

Per requirements. Some measurement jobs require calibrated, certified test equipment — regardless of the project size. Note that this requirement may not be explicitly stated but simply expected — review the specs before the test.

Monthly, quarterly, or semiannually. If you do mostly critical measurements and do them often, a shorter time span between calibrations means less chance of questionable test results.

Annually. If you do a mix of critical and non-critical measurements, annual calibration tends to strike the right balance between prudence and cost.

Biannually. If you seldom do critical measurements and don't expose your meter to an event, calibration at long frequencies can be cost-effective.

Never. If your work requires just gross voltage checks (e.g., “Yep, that's 480V”), calibration seems like overkill. But what if your instrument is exposed to an event? Calibration allows you to use the instrument with confidence.

<b>Self-Check -3</b>	<b>Written Test</b>
----------------------	---------------------

**Directions:** Answer all the questions listed below. Use the Answer sheet provided in the next page:

1. What is calibrated (1 pts)?



**TTLM**

**AHCS L-1**

2. List the causes of calibration problems (4pts).

**Note: Satisfactory rating - 3 points**

**Unsatisfactory - below 3 points**

**Answer Sheet**

Score = \_\_\_\_\_

Rating: \_\_\_\_\_

Name: \_\_\_\_\_

Date: \_\_\_\_\_



### **Occupational Health and Safety hazards in the workplace**

Occupational Health and Safety (OHS) is about working safely and ensuring that the work place is a safe place for everyone, including visitors to the Property.

It is normal to think that 'I'm Ok, nothing will happen to me.' But if we are careless around the workplace then accidents will happen. The results may be minor like a cut finger or bruised leg. However, when you think about the machinery, chemicals and other hazards on a livestock farm, you realize that it could be a very dangerous place

#### **Health and safety in laboratory**

Like any other jobs, there are professional hazards, which occur at veterinary laboratory while performing laboratory activities. Veterinary occupational health and safety policy and procedure help to reduce these veterinary occupational risks. Veterinarians, animal handlers, animal health technicians and animal health assistances can be exposed to occupational health risks, while working around animal houses & veterinary clinics. With the knowledge of what causes injuries & disease, it is easier to design and implement suitable measures to wards privations certain safety rules must be followed when attempting to capture, restrain, treat, feed or exercise animals

Accident could happen just anywhere. It could happen while you were just walking out on the streets or someplace else. But, it is especially common in workplaces. However, there are safety precautions that can be undertaken to minimize the risk. There's this thing we call safety hazard. Safety hazards may be defined as a discipline aimed at protecting the individuals from risks and impending danger. This should be highly stressed especially on workers to prevent any foreseeable accident.

This article tackles about some of the safety hazards that must be observed especially at work areas. First, you must identify what are the risks and then list down the precautionary steps that can be undertaken. One of the common hazards at work is due to fire. Fire incidents are great losses for businesses and they are most especially perilous for workers since this can even lead to the loss of lives. Here are the things that you must know and you should do in cases of fire. Foremost is that you should store combustible substances properly so as not to initiate any combustion. Electrical wiring should also be regularly checked because oftentimes fire incidents are caused by faulty wiring. Workers should not also be allowed to work alone in a big working area. Fire extinguishers should also be readily available for every fifteen feet in the work place or in any business facilities. Fire exits should



**TTLM**

**AHCS L-1**

also be cleared of any unnecessary materials so that this may facilitate easy escape especially during emergency.

It is inevitable that workers have to deal with hazardous substances in some of the work places. This is in many ways very detrimental to health. This could be inhaled, ingested, or come in contact with the skin in the form of spillage. Either way, this can cause a big damage to the body. For example, s

Inflammation or even burn the skin. You may use a mesh safety vest to protect your skin from any form of spillage. This can also be used in highway road constructions in such a way that workers should really be visible in that case. If you are also dealing with sharp materials such as steel or glass, you may wear cut resistant gloves to avoid any cuts and punctures. Other work place accidents are due to falls. Falls are usually the common cause of fatal injury each year. It is very likely that one will sustain an injury if he falls at a height beyond two meters. This is indeed a great risk for workers since it is inevitable that in work places they have to deal with tools needing some ladders or having to work with scaffolds and other elevated platforms. Painters, electricians and decorators are highly vulnerable to this. In cases like this, it is already part of the safety regulation to provide safety lines, harnesses and air beds to prevent or if not, minimize the effect of falls. Prevention is indeed better than cure. Before any of those could happen, do something so as to avoid it. The above mentioned tips are but very simple ways but would help a lot in avoiding any accidents

## **Recognising and reporting risks and hazard in the workplace**

Everyone wants a safe place to live and work. The challenge with livestock farm is that they are workplaces and also places where families live some times. For the people working on the farm, issues of animal safety includes :( livestock safety policies)

- The risk of being hurt physically by an animal that is frightened or has been startled.
- The risk of being hurt due to the misuse of equipment or equipment that is poorly maintained
- Developing allergies to animal hair, dander, or secretions such as saliva, urine, and secretions of various glands associated with the skin
- Zoonosis Diseases and microorganisms such as Salmonella, Campylobacter, Cryptosporidiosis, Q-fever, Brucellosis, Leptospirosis, enteric bacteria and parasites

### **Work in a safe manner**

Safe environment /work place are the area where professional risk is controlled or minimized to harmless level.



**TTLM**

**AHCS L-1**

Before directly joining the veterinary clinical activity, one must ensure the safety of work place. The animals, which are going to be presented to theatre, should be handled and restrained carefully.

Restraining equipments and any material used in the veterinary clinic should be checked for functional status.

Any materials which is damaged or non functional should get maintenance before work operation. Veterinary clinic environment should be clean and free of any dirty materials that may cause health problem in animals as well as workers. Waste materials that come from animals should be disposed off to avoid slipping. Slippery steps or floor that may cause falls to animals must be corrected. Electric shock is a possible danger in damp /wet areas. Electrical cords that may come into contact with water are hazards. Water that over flows or faucets that do not turn off completely may cause slippery conditions or electrical shock hazards.

**To reduce exposure to a livestock incident or illness**

- understand animal behavior
- provide proper and safe facilities
- protect against zoonotic diseases
- Wear personal protective equipment.

<b>Self-Check -4</b>	<b>Written Test</b>
----------------------	---------------------

**Directions:** Answer all the questions listed below. Use the Answer sheet provided in the next page:

1. \_\_\_\_\_ is the area where professional risk is controlled or minimized to harmless level (1 pts)
2. List at least 5 zoonosis disease (5 pts)

**Note: Satisfactory rating - 3 points**

**Unsatisfactory - below 3 points**

**Answer Sheet**

Score = _____
Rating: _____

Name: \_\_\_\_\_

Date: \_\_\_\_\_





### List of Reference Materials

#### 1- BOOKS

Roy, Baner and E.I Barger. 2003. Principles of farm machinery third edition

#### 2- WEB ADDRESSES (PUTTING LINKS)

- <https://www.jefferspet.com/blogs/livestock-blog/entries/what-you-need-to-know-about-needles-and-injections>
- <https://elearning.rcog.org.uk//easi-resource/forceps/types-forceps>
- <http://www.hse.gov.uk/work-equipment-machinery/inspection.htm>
- <http://www.hse.gov.uk/work-equipment-machinery/inspection.htm>
- <https://www.beamex.com/resources/what-is-calibration/>
- <https://www.dictionary.com/browse/calibration>
- <https://www.brighthubengineering.com/hvac/50002-calibration-of-the-measuring-instruments/>
- <https://worksmart.org.uk/health-advice/health-and-safety/hazards-and-risks/what-difference-between-hazard-and-risk>
- [https://www.ccohs.ca/oshanswers/hsprograms/hazard\\_risk.html](https://www.ccohs.ca/oshanswers/hsprograms/hazard_risk.html)
- <https://www.medicalnewstoday.com/articles/320618.php>



TTLM

AHCS L-1

# **Animal Health Care Service Level I Learning Guide -19**

**Unit of Competence: -Use and Maintain Basic  
Tools and Equipment**

**Module Title: - Using and Maintaining Basic  
Tools and Equipment**

**LG Code: AGR AHC1 M06 LO2-LG-19**

**TTLM Code: AGR AHC1 TTLM06 09 19v1**

**LO 2: Use basic tools and equipment**



<b>Instruction Sheet</b>	<b>Learning Guide #-</b>
--------------------------	--------------------------

This learning guide is developed to provide you the necessary information regarding the following **content coverage** and topics –

- Selecting, using, maintaining and storing suitable PPE clothing and equipment
- Using tools and equipment
- Completing work accordance with OHS requirements
- Identifying and reporting environmental implications associated with use and maintenance

This guide will also assist you to attain the learning outcome stated in the cover page. Specifically,

- Select, use, maintain and store suitable PPE clothing and equipment
- Use tools and equipment
- Complete Work
- Identify and report environmental implications associated with use and maintenance

#### **Learning Instructions:**

1. Read the specific objectives of this Learning Guide.
2. Follow the instructions described in number 3 to 7.
3. Read the information written in the “Information Sheets 1”. Try to understand what are being discussed. Ask you teacher for assistance if you have hard time understanding them.
4. Accomplish the “Self-check 1”,2, 3 and 4 **in page -.20,29,31 and 32**
5. Ask from your teacher the key to correction (key answers) or you can request your teacher to correct your work. (You are to get the key answer only after you finished answering the Self-check 1).
6. If you earned a satisfactory evaluation proceed to “Information Sheet 2”. However, if your rating is unsatisfactory, see your teacher for further instructions or go back to Learning Activity #1.
7. Submit your accomplished Self-check. This will form part of your training portfolio.



<b>Information Sheet-1</b>	selecting, using, maintaining and storing suitable PPE clothing and equipment
----------------------------	---

**Using personal protective**

Use proper safety clothing and personal protective equipment (PPE) that are appropriate for the tasks being performed, to reduce the risk of self injury.

**Types of PPE**

PPE can be considered in the following categories, based on the type of protection afforded by the equipment:

- Gloves: they are important to protect our hands from injury. Although there are different types of gloves, during machine operation use and sterilization it is better to use leather gloves and less extent rubber gloves
- Helmet, hat: to protect head from injury
- Goggles: protect eyes
- Mouth mask: to protect dust particles as well as splash chemicals to enter to mouth
- shoes/boot: protect the leg from injury
- Cover all: used to protect body and cloth from contamination
- Apron: protect from contamination

<b>Self-Check -1</b>	<b>Written Test</b>
----------------------	---------------------

**Directions:** Answer all the questions listed below. Use the Answer sheet provided in the next page:

1. What is the function of apron (2pt)
2. What is PPE (4)?

**Note:** <sup>1</sup> **Satisfactory rating - 3 points**

**Unsatisfactory - below 3 points**

**Answer Sheet**

Score = _____
Rating: _____

Name: \_\_\_\_\_

Date: \_\_\_\_\_



## Operation of machinery and equipments

**Microscope:** is an instrument used to see objects that are too small for the naked eye. The science of investigating small objects using such an instrument is called microscopy. Microscopic means invisible to the eye unless aided by a microscope.

Types of microscope

**Compound Microscopes:** These microscopes are mainly light illuminated and the image produced by them is two dimensional. The compound microscope is the most commonly used microscope and it is powerful enough so that the user can view cells, even the living ones. The magnification of this microscope is high but the resolution is quite low.

**Dissection Microscopes:** like the compound microscope is also light illuminated. However, it produces a three dimensional image and is commonly used for dissection of large specimen. Compared to the compound microscope, it has low magnification.

**Scanning Electron Microscope (SEM):** uses an electron illumination and produces a three dimensional image. This is an expensive microscope which has high magnification and resolution. It can take black and white pictures of the specimen.

**Transmission Electron Microscope (TEM):** like the above is also electron illuminated but provides the user with a two dimensional view. This microscope comes with high magnification and resolution

### The Parts of Microscope

**Eyepiece Lens:** the lens at the top that you look through. It remagnifies the image formed by the objective lens. They are usually 10X or 15X power.

**Body tube:** Connects the eyepiece to the objective lenses. it transmit the image from objective lens to the ocular lens.

**Arm:** Supports the body tube and ocular lens and connects it to the base



**TTLM**

**AHCS L-1**

**Base:** The bottom of the microscope, used for support

**Illuminator:** A steady light source used in place of a mirror. If your microscope has a mirror, it is used to reflect light from an external light source up through the bottom of the stage.

**Stage:** The flat platform where you place your slides. Stage clips hold the slides in place. If your microscope has a mechanical stage, you will be able to move the slide around by turning two knobs. One moves it left and right, the other moves it up and down.

**Revolving Nosepiece:** This is the part that holds two or more objective lenses and can be rotated to easily change power.

**Objective Lenses:** Usually you will find 3 or 4 objective lenses on a microscope. They almost always consist of 4X, 10X, 40X and 100X powers. The shortest lens is the lowest power; the longest one is the lens with the greatest power

**Rack Stop:** This is an adjustment that determines how close the objective lens can get to the slide. It is set at the factory and keeps students from cranking the high power objective lens down into the slide and breaking things.

**Condenser Lens:** The purpose of the condenser lens is to focus the light onto the specimen. Condenser lenses are most useful at the highest powers (400X and above). Microscopes with in stage condenser lenses render a sharper image than those with no lens (at 400X).

**Diaphragm or Iris:** Many microscopes have a rotating disk under the stage. This diaphragm has different sized holes and is used to control or vary the intensity and size of the cone of light that is projected upward into the slide. There is no set rule regarding which setting to use for a particular power. Rather, the setting is a function of the transparency of the specimen, the degree of contrast you desire and the particular objective lens in use.

**Coarse focusing knob:** used to focus when low and middle power lens in use.

**Fine focusing knob:** used to focus when high power /oil immersion lens in use.

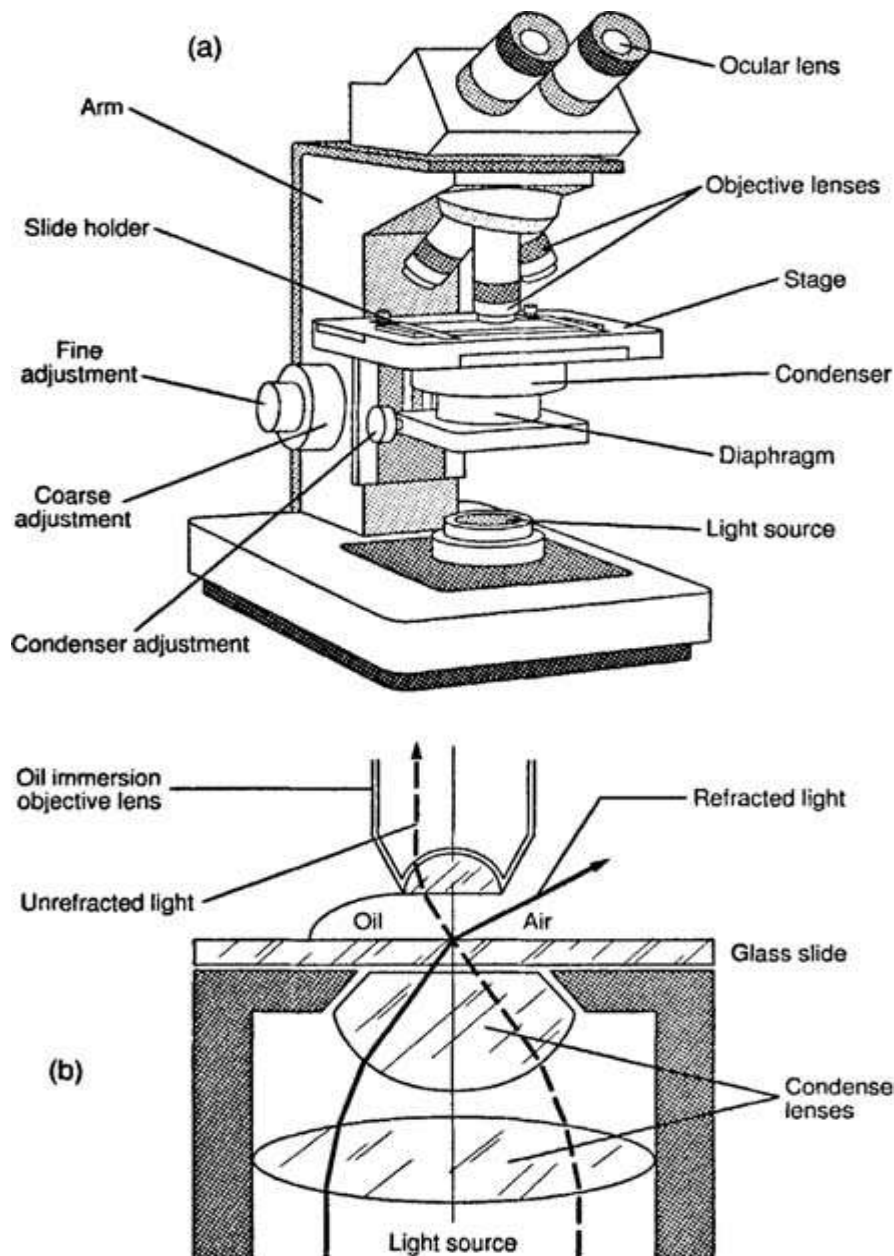

**Fig1: Microscope and its parts**

## Stethoscope

A stethoscope is a medical instrument used to listen to sounds produced in the body, especially those that emanate from the heart and lungs. Most modern stethoscopes are binaural; that is, the instrument is intended for use with both ears. Stethoscopes comprise two flexible rubber tubes running from a valve to the earpieces. The valve also connects the tubes to the chest piece, which can be either a bell-shaped piece to pick up low sounds or a flat disk for higher frequencies. The stethoscope is used mainly for the detection of heart murmurs, irregular heart rhythms, or abnormal heart sounds. It is also used to listen to the



**TTLM**

**AHCS L-1**

sound of air moving through the lungs in order to detect abnormalities in the air tubes and sacs found in the lung walls.

### **Parts of stethoscope**

**Earpiece:** The earpiece is softer knob-like objects that are put into the ear canals so that sound can be heard.

**Ear Tubes:** Ear tubes are two metal pieces that hold the earpieces and attach to the tubing.

**Tubing:** Tubing carries the sounds from the chestpiece up to the earpieces.

**Chest piece:** The chest piece, also known as the head, can be single-sided or double-sided. It is placed on the patient and captures the sounds that are transmitted up and through the earpieces.

**Chill Ring:** The chill ring provides protection from a cold chest piece being placed directly on a patient's skin.

### **Thermometer**

A **thermometer** is a device that measures temperature or temperature gradient, using a variety of different principles. A thermometer has two important elements: the temperature sensor (such as the bulb on a mercury thermometer) in which some physical change occurs with temperature, and some means of converting this physical change into a value (such as the scale on a mercury thermometer).

### **Types of thermometer**

- A. Digital thermometer
- B. mercury thermometer

Clinical thermometers were made with mercury, but today mercury thermometers are rarely seen in clinical use. The issue with a mercury clinical thermometer is that the thermometer can break, spilling mercury and posing a risk of human or animal health. Such thermometers can also be difficult to use, as they need to be held in place for several minutes, and they need to be swung to reset, as the thermometer is designed to hold the mercury in place once a maximum temperature has been reached so that the thermometer can be taken out for an accurate reading.

### **Bunsen Burner**





TTLM

AHCS L-1

A Bunsen burner is a common piece of laboratory equipment used to heat things. During use, the only part of the Bunsen burner to get hot is the top. Therefore, it is safe to handle the rest of the burner, even while it is operating. The Bunsen burner combines a flammable gas with air, which allows for a hotter flame. Methane ( $\text{CH}_4$ ) gas is fed into the burner through the gas inlet. The gas control needle valve controls the rate at which methane enters the burner. The rate at which air enters the burner is adjusted with the air control vent. Methane and oxygen mix in the burner tube and, when ignited, produce a flame.

### Parts of a Bunsen burner

- **Barrel (*burner tube*)**: is the area where the air and gas mix. It is a metal tube that screws onto the base of the burner, with small holes called air intake openings in the bottom that let air into the barrel
- **Collar**: the collar of a Bunsen burner is located around the air holes on the bottom of the barrel. The collar's function is to increase or decrease the amount of air going into the barrel; this is done through a screw mechanism.
- **air vent openings** are the holes in the collar through which the air is drawn.
- **Gas Flow Valve**: the gas flow valve of a Bunsen burner is attached to the base, directly underneath where the barrel screws on. The gas flow valve is responsible for letting gas into the barrel and can be adjusted in a similar manner to the collar—three counterclockwise turns for full gas, and clockwise turns for lesser gas or to turn the burner off completely.
- **Gas Intake Tube**: the gas intake tube is attached to the base and extends to the gas flow valve.
- **Base**: The base is designed to be heavy and sturdy to minimize incidents of Bunsen burners tipping over.

### Autoclave/steam under pressure

This apparatus is essentially a closed container in which water is boiled under pressure and consequently the temperature rises above  $100^\circ\text{C}$ . It is the most effective and widely used method of sterilization. It is lethal to spores as well as to vegetative organisms. Materials that can't resist dry heat are sterilized using autoclave such as rubber equipment, plastic material and most medias.

#### Autoclave pressures and temperatures:

5 psi  $107^\circ\text{C}$ , § 7 psi  $110^\circ\text{C}$ , § 10 psi  $115^\circ\text{C}$ , § 15 psi  $121^\circ\text{C}$ , § 20 psi  $126^\circ\text{C}$

#### Parts of autoclave



TTLM

AHCS L-1

- **Steam valve-** used to out flow of stem on autoclave
- Pressure gauge-control the autoclave pressure
- Screw caps/lids-used to closing of autoclave
- Perforated metallic basket-holding of material to be sterilize in autoclave
- Pressure cooker- used to boiling of water in the autoclave

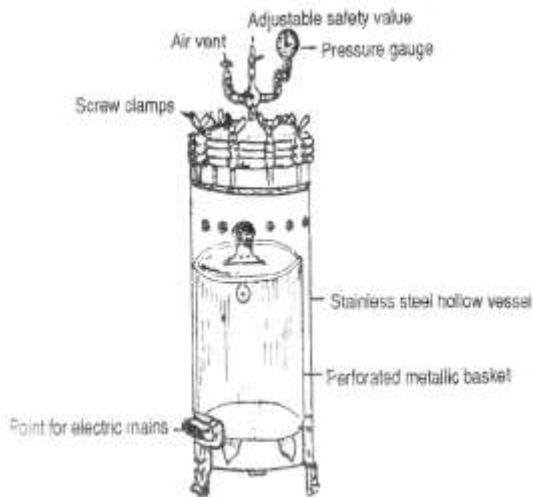

**Fig 2:** Autoclave and its parts

## Centrifuge

An apparatus used in the laboratory for separating substances of different density or particle size, when suspended in a fluid, by spinning them about an axis in a suitable container.

### Principles of centrifugation

A centrifuge is a device for separating particles from a solution according to their size, shape, density, viscosity of the medium and rotor speed. In a solution, particles whose density is higher than that of the solvent sink (sediment), and particles that are lighter than it float to the top. The greater the difference in density, the faster they move. If there is no difference in density (isopyknic conditions), the particles hover. To take advantage of even tiny differences in density to separate various particles in a solution, gravity can be replaced with the much more powerful “centrifugal force” provided by a centrifuge.

### Components of centrifuge

**Rotor:** Primary component of a centrifuge which holds the material to be subjected to centrifugal force (in some form of tube/container) and which is rotated by the drive system.

**Centrifuge tubes:** hold liquid samples

**Lid.** closing of centrifuge

**Fig3: Centrifuge**

### **Water bath**

**Water bath** is a scientific instrument used for regulating the temperature of substances subjected to heat. It is also used to sterilize needles, syringes and maintain media as liquid. The vessel of the water bath equipment is surrounded by another vessel containing water which can be kept at a desired temperature. Water baths for laboratory are used to heat those substances, which can't be heated directly on Bunsen burner or hot plate or any other such media. However only those materials can be heated with laboratory water bath whose boiling point is less than that of water.

### **Types of Water Baths**

#### **Refrigerated and Heated Circulating Water Baths**

These laboratory water baths are used for heating, cooling, and circulating. Refrigerated and heated baths offer rapid response for efficiency in the laboratory. They have inherent features like built-in safety, with over-temperature and low-liquid alerts to provide accuracy. It is mostly used in research, production or application technology, a heated/refrigerated.

#### **Shaking Water Bath**

Shaking water baths are used when the lab operation requires precise temperature control and a smooth reciprocal shaking motion. These have featuring microprocessor controls, both digital and knob control are available for operating in various speeds.

#### **Digital Water Bath**

A digital water bath for laboratory has some inherent features like programmable microprocessor-based keypad with digital display for temperature control, operation mode, and stirrer RPM. These laboratory water baths are very easy to use.

#### **Waterless Water Bath**

A waterless laboratory bath is basically a standard water bath without water. Dry, metallic beads are used to replace the water in such laboratory water bath. This type of water bath eliminates



contamination and maintenance issues.

Water baths are used in diverse fields for various purposes. Some of the industries where they are used frequently are:

- Educational Laboratories
- Clinical Laboratories
- Research Laboratories
- Food Technology Laboratories
- Waste Water Laboratories

**Hot air oven**

A hot air oven is electrical device, used to sterilize materials which can resist dry heat such as glasses and metallic materials. When available, dry heat is a practical way to sterilize needles and other instruments. A convection oven with an insulated stainless steel chamber and perforated shelving to allow the circulation of hot air is recommended, but dry-heat sterilization can be achieved with a simple oven as long as a thermometer is used to verify the temperature inside the oven. required temperature for sterilization is as follows: 120°C for 8 hours, 140°C for 3 hours 160°C for 1 hour and 180°C for 20 min.

**Effectiveness** Dry-heat sterilization is accomplished by thermal (heat) conduction. Initially, heat is absorbed by the exterior surface of an item and then passed to the next layer. Eventually, the entire object reaches the temperature needed for sterilization. Death of microorganisms occurs with dry heat by a process of slow destruction of protein. Dry-heat sterilization takes longer than steam sterilization, because the moisture in the steam sterilization process significantly speeds up the penetration of heat and shortens the time needed to kill microorganisms

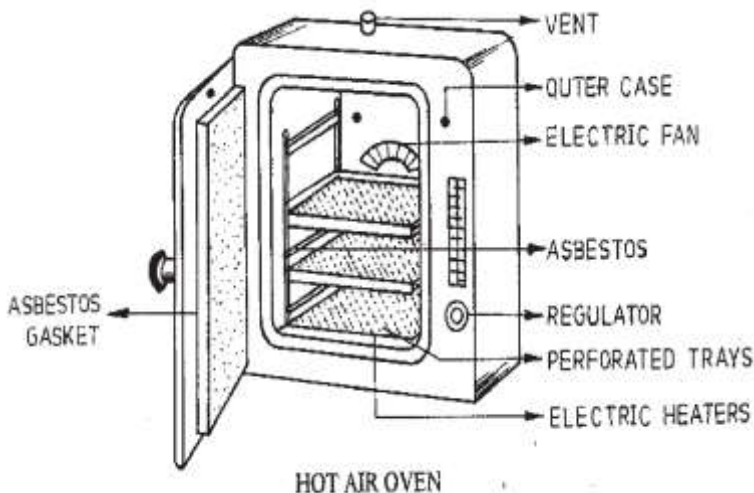



TTLM

AHCS L-1

**Fig 4: Hot air oven and its parts**

<b>Self-Check –3</b>	<b>Written Test</b>
----------------------	---------------------

**Directions:** Answer all the questions listed below. Use the Answer sheet provided in the next page:

1. Write types of microscope (4 pts).
2. What is the function of water bath (2 pts)?

**Note: Satisfactory rating - 3 points**

**Unsatisfactory - below 3 points**

**Answer Sheet**

Score = _____
Rating: _____

Name: \_\_\_\_\_

Date: \_\_\_\_\_



<b>Information Sheet-3</b>	<b>Completing work in accordance with OHS requirements</b>
----------------------------	--

The purpose of the Health and Safety **policies and procedures** is to guide and direct all employees to work safely and prevent injury, to themselves and others. All employees are encouraged to participate in developing, implementing, and enforcing Health and Safety **policies and procedures**. To complete the given task we must follow OHS requirements

☞ **Use of appropriate personal protective equipment (PPE):**

It is used to prevent hazards in work place. Personal protective equipment may includes: Safety goggles, gloves, Helmet, cover all, mouth mask, apron and Safety shoes.

☞ **Equipment and chemical handling and use safety rules and procedures**

Always follow these guidelines when working with chemicals:

- ✓ Assume that any unfamiliar chemical is hazardous.
- ✓ Know all the hazards of the chemicals with which you work. For example, perchloric acid is a corrosive, an oxidizer, and a reactive. Benzene is an irritant that is also flammable, toxic, and carcinogenic.
- ✓ Consider any mixture to be at least as hazardous as its most hazardous component.
- ✓ Never use any substance that is not properly labeled.
- ✓ Follow all chemical safety instructions precisely.
- ✓ Minimize your exposure to any chemical, regardless of its hazard rating.
- ✓ Use personal protective equipment, as appropriate.

**The five prudent practices of chemical safety sum up these safety guidelines:**

- ✓ Treat all chemicals as if they were hazardous.
- ✓ Minimize your exposure to any chemical.
- ✓ Avoid repeated exposure to any chemical.
- ✓ Never underestimate the potential hazard of any chemical or combination of chemicals.
- ✓ Assume that a mixture or reaction product is more hazardous than any component or reactant.

### **Hygiene and Chemical Safety**

Good personal hygiene will help minimize exposure to hazardous chemicals. When working with chemicals, follow these guidelines:

- ✓ Wash hands frequently and before leaving the laboratory. Also, wash hands before eating, drinking, smoking, or applying makeup.
- ✓ Remove contaminated clothing immediately. Do not use the clothing again until it has been properly decontaminated.
- ✓ Follow any special precautions for the chemicals in use.

In addition, follow these special precautions:



TTLM

AHCS L-1

- ✓ Do not eat, drink, smoke, or apply makeup around chemicals
- ✓ Do not wear contact lenses near chemicals, especially corrosives or volatile solvents
- ✓ Do not keep food or food containers anywhere near chemicals
- ✓ Do not use laboratory equipment to serve or store food or drinks
- ✓ Do not sniff or taste chemicals

#### ☞ Personal hygiene

**Hygiene** generally refers to the set of practices associated with the preservation of health and healthy living. The focus is mainly on personal hygiene that looks at cleanliness of the hair, body, hands, fingers, feet and clothing etc.

Improvements in personal knowledge, skill and practice that modify an individual's behaviour towards healthy practice are the focus of hygiene promotion. Safe hygiene practice includes a broad range of healthy behaviours, such as hand washing before eating and after cleaning a child's bottom, and safe faeces disposal.

**Sanitation** means the prevention of human contact with wastes, for hygienic purposes. It also means promoting health through the prevention of human contact with the hazards associated with the lack of healthy food, clean water and healthful housing, the control of **vectors** (living organisms that transmit diseases), and a clean environment. It focuses on management of waste produced by human activities.

#### **A.HAND HYGIENE**

Consistent, thorough hand hygiene is the single most important measure veterinary personnel can take to reduce the risk of zoonotic disease transmission. Most common pathogens are transmitted by hand-to-mouth contact either directly from animals or indirectly through the environment

<b>Self-Check –3</b>	<b>Written Test</b>
----------------------	---------------------

**Directions:** Answer all the questions listed below. Use the Answer sheet provided in the next page:

1. What is importance OHS (1 pts)
2. List the five prudent practices of chemical safety guidelines (5 pts)

**Note: Satisfactory rating - 3 points**

**Unsatisfactory - below 3 points**

#### **Answer Sheet**

Score = \_\_\_\_\_

Rating: \_\_\_\_\_

Name: \_\_\_\_\_

Date: \_\_\_\_\_



<b>Information Sheet-4</b>	<b>Identifying and reporting environmental implications associated with use and maintenance</b>
----------------------------	---

Identifying and reporting environmental implications associated with use and maintenance  
 Equipment noise impacts wildlife and people, and is a hazard to workers even more than the general public. Asking contractors to buy quieter equipment when they buy new equipment tops workers lists of requests; unions, equipment manufacturers, and contractors are beginning to tackle the issue.

Source controls, which limit noise emissions, are the most effective methods of eliminating noise problems. Source mitigation reduces the noise problem everywhere not just along a single path or for one receiver. Consequently, a project's noise mitigation strategy should emphasize noise control at the source. Source controls that limit noise emissions or restrict allowable types or operating times of heavy equipment are the easiest to oversee on a construction project.

Instream and offshore blasting are used during bridge or culvert construction to fracture bedrock or free materials that are difficult to excavate. Fish near blast sites may be killed or severely injured as a result of swim bladder rupture, tissue and organ damage or internal bleeding. Fish habitat may be affected by changes in downstream water quality, sedimentation, or the physical destruction of habitat at the blast site. Blasting mitigation minimizes or eliminates the potential for negative effects on fish or fish habitat that might occur as a result of the instream or onshore use of explosives during bridge or culvert construction

<b>Self-Check –4</b>	<b>Written Test</b>
----------------------	---------------------

**Directions:** Answer all the questions listed below. Use the Answer sheet provided in the next page:

1. What are the **environmental implications associated with use and maintenance** of tool and equipment (2pts)

**Note: Satisfactory rating - 2 points**

**Unsatisfactory - below 2 points**

**Answer Sheet**

Score = _____
Rating: _____





Name: \_\_\_\_\_

Date: \_\_\_\_\_

**Operation Sheet 1****operating microscope**

## Procedures

1. To carry the microscope grasp the microscopes arm with one hand. Place your other hand under the base
2. Place the microscope on a table with the arm toward you.
3. Turn the coarse adjustment knob to raise the body tube
4. Revolve the nosepiece until the low-power objective lens clicks into place.
5. Adjust the diaphragm. While looking through the eyepiece, also adjust the mirror until you see a bright white circle of light.
6. Place a slide on the stage. Center the specimen over the opening on the stage. Use the stage clips to hold the slide in place.
7. Look at the stage from the side. Carefully turn the coarse adjustment knob to lower the body tube until the low power objective almost touches the slide.
8. Looking through the eyepiece, VERY SLOWLY the coarse adjustment knob until the specimen comes into focus.
9. To switch to the high power objective lens, look at the microscope from the side. CAREFULLY revolve the nosepiece until the high-power objective lens clicks into place. Make sure the lens does not hit the slide.
10. Looking through the eyepiece, turn the fine adjustment knob until the specimen comes into focus.

**Operation Sheet 2****apply thermometer on animals****Procedures:**

- (A) The thermometer should be sterilized by disinfectant (antiseptics) before use;



**TTLM**

**AHCS L-1**

(B) It should be well shaken before recording of temperature to bring the mercury column down below the lowest point likely to be observed in different species of animals.

(C) The bulb end of the thermometer should be lubricated with liquid paraffin or glycerine or soap especially in case of small pup and kitten.

(D) Care should be taken so that the bulb of the thermometer remains in contact with the rectal mucous membrane.

(E) The thermometer should be kept in site for at least 3-5 minutes.

(F) Read the thermometer

<b>Operation Sheet 3</b>	<b>Operating Autoclave</b>
--------------------------	----------------------------

**Procedures:**

- 1 Put a little water in the bottom of the pressure cooker.
2. Prepare the material to be sterilize
3. Load the material to be sterilized into the autoclave.
4. Screw down the lid.
5. Open the steam valve.
6. Switch on. If there are high and low switches on the autoclave make sure both are switched on.
7. Let steam come out for at least five (5) minutes before closing steam valve. Continue heating until the pressure is up to 15 psi.
8. Adjust pressure and turn the heat down or the high switch off.
9. Leave to steam for the appropriate time then turn off the autoclave.
10. Leave to cool to reduce the pressure to zero.
11. Open the steam valve to release any remaining pressure.
12. Wait five (5) minutes before opening the lid.
13. Open the lid and unload the material in the autoclave



TTLM

AHCS L-1

<b>Operation Sheet 4</b>	<b>Hot air oven operating instructions</b>
--------------------------	--

**Procedures:**

- Arrange the material to be sterilized loosely and evenly on the racks of the oven allowing free circulation of air and thereby even heating of the load.
- If desired, wrap instruments by aluminum foil or place in a metal container or by trays
- Do not pack the load tightly since air is a poor conductor of heat.
- Switch on the power supply and control the temperature of the oven by adjusting the thermostat.
- Note the time when the desired temperature is reached (heating-up time).
- Hold the load in the oven at this temperature for a definite period of time (holding period). This is usually 60 minutes at 160°C.
- Do not overheat since it would char the cotton plugs and paper wrappings.
- Cool down the oven
- After cooling remove packs or metal containers and store.

<b>Operation Sheet 5</b>	<b>Operation of water bath</b>
--------------------------	--------------------------------

**Procedures:**

- set up on a stable surface, away from flammable and combustible materials including wood and paper
- Put a little water in the bottom of the water bath.
- Prepare the material to be sterilize
- Load the material to be sterilized into the water bath.
- Switch on water bath and heat for a given period of time
- Turn off the heat down or the high switch off.
- Leave to cool to reduce heat of water bath.
- unload the material in the water bath

<b>Operation Sheet 6</b>	<b>How to light and adjust a bunsen burner</b>
--------------------------	--

**Procedures:**



**Step 1.** Connect the burner hose to the gas outlet. The gas outlet handle should be in the fully closed position with the handle at a right angle to the outlet pipe.

**Step 2.** Turn the gas valve on the gas outlet to the fully open position (handle is now parallel to gas outlet).

**Step 3.** With the main gas valve fully open; open the gas adjustment at the base of the burner by several turns to give

**Step 4.** Light the burner by holding a match to the side of the mouth of the burner. If you stick the match in the middle of the gas stream, the flame is usually blown out before the burner lights.

**Step 5.** Adjust the amount of air in the flame by turning the barrel of the burner. A flame with too little air mixed in it has a light blue, bushy appearance (see left) and more air must be mixed in by unscrewing the barrel to the left.

### List of Reference Materials

#### 1. BOOKS

Roy, Baner and E.I Barger. 2003. Principles of farm machinery third edition

#### 2. WEB ADDRESSES (PUTTING LINKS

- <https://safetyculture.com/topics/ppe-safety/>
- <http://www.hse.gov.uk/toolbox/ppe.htm>
- <https://study.com/academy/lesson/hot-air-oven-for-sterilization-definition-working-principle.html>
- <https://www.labequipmentglobal.com/product/circulating-water-bath?>
- <https://www.fss.txstate.edu/ehsrm/safetymanual/chemical/gensftygu.html>
- <http://www.hse.gov.uk/work-equipment-machinery/maintenance.htm>



TTLM

AHCS L-1

# **Animal Health Care Service Level I**

# **Learning Guide -20**

**Unit of Competence: -Use and Maintain Basic  
Tools and Equipment**

**Module Title: - Using and Maintaining Basic  
Tools and Equipment**

**LG Code: AGR AHC1 M06 LO1-LG-20**

**TTLM Code: AGRAHC1 TTLM06 09 19v1**

**Lo3: .Check, clean and store basic tools and equipment**



Instruction Sheet	Learning Guide #-
-------------------	-------------------

This learning guide is developed to provide you the necessary information regarding the following **content coverage** and topics –

- Detailing and recording of tools and equipment use
- cleaning, securing and storing tools and equipment
- identifying and reporting malfunctions, faults, wear or damage tools and equipment
- cleaning and maintaining Workplace areas

This guide will also assist you to attain the learning outcome stated in the cover page. Specifically,

- Detail and record tools and equipment use
- clean, secure and store malfunctions, faults, wear or damage tools and equipment
- identifying and reporting malfunctions, faults, wear or damage tools and equipment
- cleaning and maintaining Workplace areas

#### **Learning Instructions:**

2. Read the specific objectives of this Learning Guide.
3. Follow the instructions described in number 3 to 7.
4. Read the information written in the “Information Sheets 1”. Try to understand what are being discussed. Ask you teacher for assistance if you have hard time understanding them.
5. Accomplish the “Self-check 1”,2,3,and 4 **in page -.41, 44, 46 and 53 respectively**
6. Ask from your teacher the key to correction (key answers) or you can request your teacher to correct your work. (You are to get the key answer only after you finished answering the Self-check 1).
7. If you earned a satisfactory evaluation proceed to “Information Sheet 2”. However, if your rating is unsatisfactory, see your teacher for further instructions or go back to Learning Activity #1.
8. Submit your accomplished Self-check. This will form part of your training portfolio.



Information Sheet-1	Detailing and recording of tools and equipment use
---------------------	--

Detailing and recording of tools and equipment use are important to use and maintain tools and equipment appropriately, to save time and space, for material and personal safety and to identify the faulty and damage tools from the normal one. in genera apply 5s at all time while using tools and equipment's

Self-Check –1	Written Test
---------------	--------------

**Directions:** Answer all the questions listed below. Use the Answer sheet provided in the next page:

1. What is the advantage of detail recording of material use (4pts)?

**Note: Satisfactory rating - 2 points**

**Unsatisfactory - below 2 points**

**Answer Sheet**

Score = _____
Rating: _____

Name: \_\_\_\_\_

Date: \_\_\_\_\_

**Information Sheet-2****Cleaning , securing and storing tools and equipment****Maintain and check equipment correctly**

A maintenance schedule should be in place to ensure that your equipment is maintained at least at intervals indicated in the manufacturer's operating instructions or more frequently if indicated by the risk assessment. Any daily checks should be undertaken as recommended by the manufacturer. This will help prevent problems such as blockages, leaks or breakdowns, which can increase risks.

Some types of equipment - from gas appliances and lifting equipment to pressure systems and power presses - require examinations by law, often known as thorough examinations by a **competent person**, in addition to normal repair and servicing. You need to keep the certificates and records of such checks, detailing the findings and any remedial work carried out to correct faults that were identified.

In addition to the equipment itself, you'll also need to maintain safety devices around the equipment such as guards, alarms, safety cages and warning signs.

If you use heat-producing equipment you should regularly check the environment around it. Floors should be kept clear and there must be adequate ventilation at all times. You also need to remove all combustible materials from the area and regularly maintain and check fire detectors.

If any equipment is to be checked or repaired, it should always be turned off and isolated so it can't be started in error.

Most equipment now comes with guidelines for maintenance, including advice on how to carry out equipment checks safely.

Many businesses find it useful to establish documented procedures for maintenance and repair work, such as a permit to work scheme. You can also use warning signs as a visible





**TTLM**

**AHCS L-1**

reminder that equipment is temporarily out of use and/or a lock out system, ie the person doing the maintenance work has a key that prevents the equipment starting up while they work on it.

➤ **Microscope cleaning and Storage**

☞ **Microscope cleaning**

→ **Cleaning Solutions and Solvents**

- ✓ Soap solution for cleaning of body and stage
- ✓ Ether-Alcohol, Alcohol, or Lens Cleaner Solution for cleaning of lenses
- ✓ Refer to manufacturer's guide for appropriate organic solvent

→ **Cleaning Materials**

- ✓ Lint-free cotton gauze pads
- ✓ Lint-free cotton swabs
- ✓ Lens paper

**Alternatives include:**

- ✓ Fine quality tissue paper
- ✓ Muslin cloth
- ✓ Silk

**I. Microscope Cleaning Process**

- Cleaning the Eyepiece
- Cleaning the Objectives
- Cleaning the Microscope Stage
- Cleaning the Microscope Body
- Cleaning the Condenser

**Step 1: Cleaning the Eyepieces**

- ✓ Blow to remove dust before wiping lens
- ✓ Clean the eyepieces with a cotton swab moistened with lens cleaning solution
- ✓ Clean in a circular motion inside out

**Step 2: Cleaning the Objectives**

- ✓ Objectives are cleaned while attached to microscope
- ✓ Moisten the lens paper with the cleaning solution
- ✓ Wipe gently the objective in circular motion from inside out
- ✓ Wipe with dry tissue or lens cleaning paper
- ✓ Objectives should never be removed from the nosepiece.

**Step 3: Cleaning the Microscope Stage**



**TTLM**

**AHCS L-1**

- ✓ Wipe the microscope stage using the cleaning solution on a soft cloth
- ✓ Thoroughly dry the stage
- ✓ Repeat above steps, if required

**Step 4: Cleaning the Microscope Body**

- ✓ Unplug the microscope from power source
- ✓ Moisten the cotton pad with a mild cleaning agent
- ✓ Wipe the microscope body to remove dust, dirt, and oil
- ✓ Repeat steps 1–3, if required

**Step 5: Cleaning the Condenser and Auxiliary Lens**

- ✓ Unplug the microscope from power source
- ✓ Clean the condenser lens and auxiliary lens using lint-free cotton swabs moistened with lens cleaning solution
- ✓ Wipe with dry swabs

**II. Microscope Storage**

- ✓ Proper storage of the microscope will prevent or reduce problems!
- ✓ Optics and mechanisms of the microscope must be protected from:
  - Dust and dirt
  - Fungus

**•Store the microscope**

- Under a protective cover
- In a low humidity environment

<b>Self-Check –2</b>	<b>Written Test</b>
----------------------	---------------------

**Directions:** Answer all the questions listed below. Use the Answer sheet provided in the next page:

1. What is the important of maintenance (4 pts)

**Note: Satisfactory rating - 2 points**

**Unsatisfactory - below 2 points**

**Answer Sheet**

Score = _____
Rating: _____



TTLM

AHCS L-1

Name: \_\_\_\_\_

Date: \_\_\_\_\_

<b>Information Sheet-3</b>	<b>Identifying and reporting malfunctions, faults, wear or damage tools and equipment</b>
----------------------------	---

Machine related problems can occur at the start of the day, during the warm-up period, or during the treatment day. Obvious dosimetry problems, such as miscalibration of the beam or lack of symmetry/flatness, are readily apparent only during the morning checks (assuming the standard daily procedure includes the appropriate tests). The most frequent problems can be classified into three categories:

- (a) Clear breakdowns-no beam,
- (b) Machine suffers frequent interlock interrupts-beam available if radiation therapy technologist continually resets interlock; and
- (c) Machine gives occasional problems that can easily be overridden by radiation therapy technologist.

Once the fault has been diagnosed and corrected for category (a) failures, the decision as to whether to recalibrate or rescan the beam can easily be made.

The immediate concern with categories (b) and (c) is to ensure that the radiation therapy technologist reports such problems promptly. If full time engineering or physics personnel are available, these problems would be reported to them for resolution. If only physics personnel are on hand, the severity of the problem can be assessed and, if necessary, the manufacturer's service personnel contacted.

The most difficult situation is when there is no technical backup available to the technologist. Frequently, the vendor's service personnel are not immediately available, and the technologist is left to decide what action to take. It is obviously more convenient to try to



**TTLM**

**AHCS L-1**

continue with treatment, since this avoids lengthy downtimes. However, seemingly benign faults that are easily reset can be misleading.

For example, even “UNDERDOSE” faults can be indicative of severe overdoses. Thus, if the radiation therapy technologists are able to finish the treatment, regardless of how many times the reset and start buttons are pressed, there is the temptation to do so. It should be made clear to the technologists that this response is not acceptable, because it can lead to potentially serious overdoses. However, two questions arise: at what frequency of fault appearances should the radiation therapy technologist report the machine as malfunctioning, and, more importantly, should patients continue to be treated on the machine?

If a fault occurs more than two or three times during a treatment day, the appropriate service personnel should be notified. It may or may not be possible to duplicate the fault, but by observing the treatments for an hour or so the engineer may be able to see the fault firsthand.

However, in cases where the problem has been encountered before, is well understood, no change in the dosimetry is anticipated, and the corrective action is simple, all this may be unnecessary. However, where faults are occurring at the rate of one or more per treatment, then immediate service action is required and treatments should be suspended.

<b>Self-Check –4</b>	<b>Written Test</b>
----------------------	---------------------

**Directions:** Answer all the questions listed below. Use the Answer sheet provided in the next page:

1. What is the important of identifying and reporting of damaged tools and equipments (4 pts)

**Note: Satisfactory rating - 2 points**

**Unsatisfactory - below 2 points**

**Answer Sheet**

Score = \_\_\_\_\_

Rating: \_\_\_\_\_

Name: \_\_\_\_\_

Date: \_\_\_\_\_

**Information Sheet-4****Cleaning and maintaining workplace areas**

Regular maintenance is essential to keep equipment, machines and the work environment safe and reliable. Lack of maintenance or inadequate maintenance can lead to dangerous situations, accidents and health problems. Maintenance is a high-risk activity with some of the hazards resulting from the nature of the work. Maintenance is carried out in all sectors and all workplaces. Therefore, maintenance workers are more likely than other employees to be exposed to various hazards

Maintenance is a generic term for variety of tasks in very different types of sectors and all kinds of working environments. Maintenance activities include:

- **inspection**
- **testing**
- **measurement**
- **replacement**
- **adjustment**
- **repair**
- **upkeep**
- **fault detection**
- **replacement of parts**
- **servicing**
- **Lubrication**
- **cleaning**

Maintenance is critical to ensure continuous productivity, to produce products of high quality and to keep company's competitiveness. But it also has an impact on occupational safety and health.

Firstly, **good maintenance is essential to keep machines and work environment safe and reliable**. Secondly, maintenance itself is **a high-risk activity** and it **has to be**



**performed in a safe way**, with appropriate **protection of maintenance workers** and other people present in the workplace.

Regular maintenance has an important role in **eliminating workplace hazards** and providing safer and healthier working conditions. **Lack of maintenance or inadequate maintenance can cause serious and deadly accidents or health problems.**

Accidents happen due to **faulty electrical installations** (cables, plugs, equipment)

- Shock and burns, fires, ignition of potentially flammable or explosive atmospheres

Accidents happen because **lifting equipment is not inspected and not maintained** regularly

- lifting chains are dirty/corroded and fail, causing heavy load to fall
- Accidents happen as a **result of lack of maintenance of working and walking surfaces and traffic routes** uneven, potholed, sloped or slippery surfaces cause `fork-lift truck accidents, slips and trips
- **Dust** poses a **potential health risk** to workers in woodworking industry, quarries.

Maintenance of **dust control equipment** is crucial in all dust producing processes to prevent exposure of workers to dust

- ventilation ducts must be kept free from blockages and repaired if damaged
- filter units need to be maintained regularly according to manufacturer's recommendations

Equipment should be constructed so that surfaces that contact raw materials, intermediates, or APIs are not reactive, additive, or absorptive so as to alter the quality and purity of the API and/or intermediate beyond the official or other established specifications. Any substances required for operation, such as lubricants, heating fluids, or coolants, should not contact raw materials, packaging materials, intermediates, or APIs so as to alter the quality and purity of APIs and intermediates beyond the official or other established specifications.

Where feasible, equipment should be designed, constructed, and installed to allow for ease of cleaning, and, as applicable, sanitization. Qualification of equipment should ensure that:

It is installed according to approved design specifications, regulatory codes, and the equipment manufacturers' recommendations. The equipment operates within limits and tolerances established for the process. Written procedures should be established and followed for cleaning and maintaining equipment, including utensils and storage vessels, used in the manufacture, processing, packing, or holding of APIs and intermediates. Procedures should, at a minimum, include:



**TTLM**

**AHCS L-1**

- Assigning responsibility for cleaning and maintaining equipment;
- Establishing maintenance and cleaning schedules, including, where appropriate,
- sanitizing schedules;

Maintenance facilities, including tools, equipment and supplies predominantly used in performing the work (For example: chain, hoists, tire spreaders, welding equipment, drills, sanders, wrenches, paint brushes and sprayers, oilers, absorbent compounds, dusting compounds, air blowers and wipers) shall be subject to tax. However, replacement parts which are used to replace worn parts upon exempt machinery and equipment (For example: motors, belts, screws, bolts, cutting edges, air filters or gears) and operating supplies which are actively and continuously used in the operation of exempt machinery and equipment (For example: fuel, lubricants, paint and compressed air) shall be exempt from tax. Equipment and supplies, including soaps and cleaning compounds, brushes, brooms, mops, and similar items, used in general cleaning and maintenance of manufacturing or processing property shall be subject to tax. Installation and repair of property for others is not manufacturing or processing, whether the work is performed for or by a manufacturer or processor. This is so whether the property installed or repaired is manufactured or processed by the installer or repairman or someone else.

Equipment and utensils should be cleaned, held and, where necessary, sanitized at appropriate intervals to prevent contamination or cross-contamination that would alter the quality or purity of the API or intermediate beyond the official or other established specifications.

Dedicated equipment should be cleaned at appropriate intervals to prevent the build-up of objectionable material or microbial growth. As processing approaches the purified API, it is important to ensure that incidental carryover of contaminants or degradants between batches does not adversely impact the established impurity profile. However, this does not generally apply to biologic APIs, where many of the processing steps are accomplished aseptically and where it is often necessary to clean and sterilize equipment between batches.

Nondedicated equipment should be thoroughly cleaned between different products and, if necessary, after each use to prevent contamination and cross-contamination. If cleaning a specific type of equipment is difficult, the equipment may need to be dedicated to a particular API or intermediate.



The choice of cleaning methods, cleaning agents, and levels of cleaning should be established and justified. When selecting cleaning agents (e.g., solvents) the following should be considered

The cleaning agent's ability to remove residues of raw materials, precursors, by-products, intermediates, or APIs;

- Whether the cleaning agent leaves a residue itself; and
- Compatibility with equipment construction materials

## **Cleaning**

Cleaning is the removal of all foreign material (dirt and organic matter) from the object being reprocessed. Two key components of cleaning are friction to remove foreign matter and fluids to remove or rinse away contamination.

Thorough cleaning will remove most organisms from a surface and should always precede disinfection and sterilization procedures. If instruments and other items have not been cleaned, sterilization and disinfection may not be effective because microorganisms trapped in organic material may survive sterilization or disinfection.

Cleaning is normally accomplished by the use of water, detergents and mechanical actions. Detergent is essential to dissolve proteins and oil that can reside on instruments and equipment after use.

Cleaning may be manual or mechanical. Mechanical cleaning includes ultrasonic cleaners or washer/disinfectors that may facilitate cleaning and decontamination of some items and may reduce the need for handling.

The solution used most often to clean is an enzymatic presoak (protease formula that dissolves protein). Alternatively a detergent can be used. Detergents lower surface tension and lift dirt or oil away from the device.

Studies have shown that thorough cleaning alone can provide a 10 000 fold reduction in contaminant microbes from endoscopes. 79, 81, 82 Cleaning can be very effective in removing microbial contaminants from surgical devices.

## **Mechanical Cleaning**





**TTLM**

**AHCS L-1**

Most modern sterilization units are automated and there is minimal handling of dirty equipment by staff. The equipment is placed in trays ready for washing:

- Washing machine. The washing machine gives a cold rinse followed by a hot wash at 71 °C for 2 minutes. This is followed by a 10-second hot water rinse at 80-90 °C and then by drying by a heater or a fan at 50-75 °C. Relation between type of item & its decontamination
- Washer/disinfector. The washer/disinfector is used for anesthetic equipment. It runs a 45-minute cycle of washing and cleaning plus a 2-minutes cycle with water at 80-100 °C and with a detergent solution.
- Ultrasonicator. The ultrasonicator is a sophisticated and expensive but extremely efficient piece of equipment. It uses high-power output of 0.44 W/cm<sup>3</sup> and dislodges all organic matter.

### **Manual Cleaning**

All items requiring disinfection or sterilization should be dismantled before cleaning. Cold water is preferred; it will remove most of the protein materials (blood, sputum, etc.) that would be coagulated by heat and would subsequently be difficult to remove. The most simple, cost-effective method is to thoroughly brush the item while keeping the brush below the surface of the water in order to prevent the release of aerosols. The brush should be decontaminated after use and should be dried.

Finally, items should be rinsed in clean water and then should be dried. Items are then ready for use (noncritical items) or for disinfection (semi-critical items) or for sterilization (critical items).

Manual cleaning is necessary when:

- Mechanical cleaning facilities are not available;
- Delicate instruments have to be cleaned;
- Complex instruments need to be taken apart to be cleaned;
- Items with narrow lumens need to be cleaned (endoscopes).

Manual or hand-cleaning must be done with extreme caution. The staff should follow the set procedure:



**TTLM**

**AHCS L-1**

Remember when cleaning:

- Do not use hand soap to clean instruments because fatty acids in the soap react with hard water to leave a soap scum on the instruments.
- Always wear utility gloves, a mask, and eye protection when cleaning instruments.
- Do not use abrasive materials that scratch or pit instruments. Scratches, pits, or grooves can harbor microorganisms and promote corrosion.

Automatic washing machines are preferable to washing by hand.

**Soaking of Instruments Prior to Cleaning** Sometimes the level of contamination of the instrument makes it necessary to soak items prior to cleaning (e.g. instruments in operating theatres). A deep container, e.g. a bucket, containing a wire-mesh basket can be filled with water and detergent. The instruments are placed in the wire basket, agitated for 3-5 minutes, and then lifted out. The basket is overturned onto a table or tray in order to separate the instruments prior to cleaning, packing and autoclaving.

## **Disinfection**

Disinfection can be carried out either by thermal or chemical processes.

Thermal disinfection is preferred whenever possible. It is generally more reliable than chemical processes, leaves no residues, is more easily controlled, and is non-toxic. Heat sensitive items have to be reprocessed with a chemical disinfectant.

Organic matter (serum, blood, pus or fecal material) interferes with the antimicrobial efficiency of either method. The larger the number of microbes present, the longer it takes to disinfect. Thus scrupulous cleaning before disinfection is of greatest importance.

**High Level Disinfection (HLD) - Semi-critical Items**

There are three types of HLD:

- Disinfection by boiling
- Moist heat at 70-100°C
- Chemical disinfection



**TTLM**

**AHCS L-1**

**Note:** When sterilization is not available, HLD is the only acceptable alternative for instruments and other items (=semi-critical items) that will come into contact with the bloodstream or tissues under the skin.

Boiling is HLD, not sterilization. Flaming is not an effective method of HLD because it doesn't effectively kill all microorganisms.



<b>Self-Check –4</b>	<b>Written Test</b>
----------------------	---------------------

**Directions:** Answer all the questions listed below. Use the Answer sheet provided in the next page:

- 2. What is cleaning (2pts)
- 3. What is disinfection (2pts)

**Note: Satisfactory rating - 2 points**

**Unsatisfactory - below 2 points**

**Answer Sheet**

Score = _____
Rating: _____

Name: \_\_\_\_\_

Date: \_\_\_\_\_

<b>Operation Sheet 1</b>	<b>cleaning of tools and equipment</b>
--------------------------	--

**Procedures:**

- 1. Wear heavy-duty rubber gloves, a plastic apron, eye protection, and mask during cleaning.
- 2. Soak the instruments in normal tap water containing a detergent.
- 3. Scrub instruments and other items vigorously to completely remove all foreign material using a soft brush or old toothbrush, detergent, and water. Hold items under the surface of the water while scrubbing and cleaning to avoid splashing. Disassemble instruments and other items with multiple parts, and be sure to brush in the grooves, teeth, and joints to items where organic material can collect and stick.
- 4. Flush through lumens with an adapted water jet.
- 5. Rinse items thoroughly with clean water to remove all detergent. Any detergent left on the items can reduce the effectiveness of further processing.



**TTLM**

**AHCS L-1**

6. Inspect items to confirm that they are clean.

7. Allow items to air dry or dry them with a clean towel if chemical disinfection is going to be used. This is to avoid diluting the chemical solutions used after cleaning. Items that will be high-level disinfected by boiling or steaming do not need to be dried.

<b>LAP Test</b>	<b>Practical Demonstration</b>
-----------------	--------------------------------

Name: \_\_\_\_\_ Date: \_\_\_\_\_

Time started: \_\_\_\_\_ Time finished: \_\_\_\_\_

**Instructions:** Given necessary templates, tools and materials you are required to perform the following tasks within --- hour.

### **Task 1. Perform cleaning of tools and equipments**

<b>List of Reference Materials</b>
------------------------------------

#### **1. BOOKS**

Roy, Baner and E.I Barger. 2003. Principles of farm machinery third edition

#### **2. WEB ADDRESSES (PUTTING LINKS)**

→ <https://tuttnauer.com/blog/veterinary-equipment-what-you-need-when-setting-clinic>

→ <https://www.dreveterinary.com/veterinary-equipment>

→ [https://www.microscopeworld.com/t-microscope\\_maintenance.aspx](https://www.microscopeworld.com/t-microscope_maintenance.aspx)

→ <http://www.microscopy-uk.org.uk/mag/indexmag.html>

→ [https://www.ccohs.ca/oshanswers/safety\\_haz/power\\_tools/saf\\_elec.html](https://www.ccohs.ca/oshanswers/safety_haz/power_tools/saf_elec.html)

→ <http://www.iloencyclopaedia.org/part-xvi-62216/construction/content/tools-equipment-and-materials>

→ <https://laally.com/pages/cleaning>

→ <https://extension.psu.edu/disinfecting-tools-equipment-pots-flats-and-benches>